

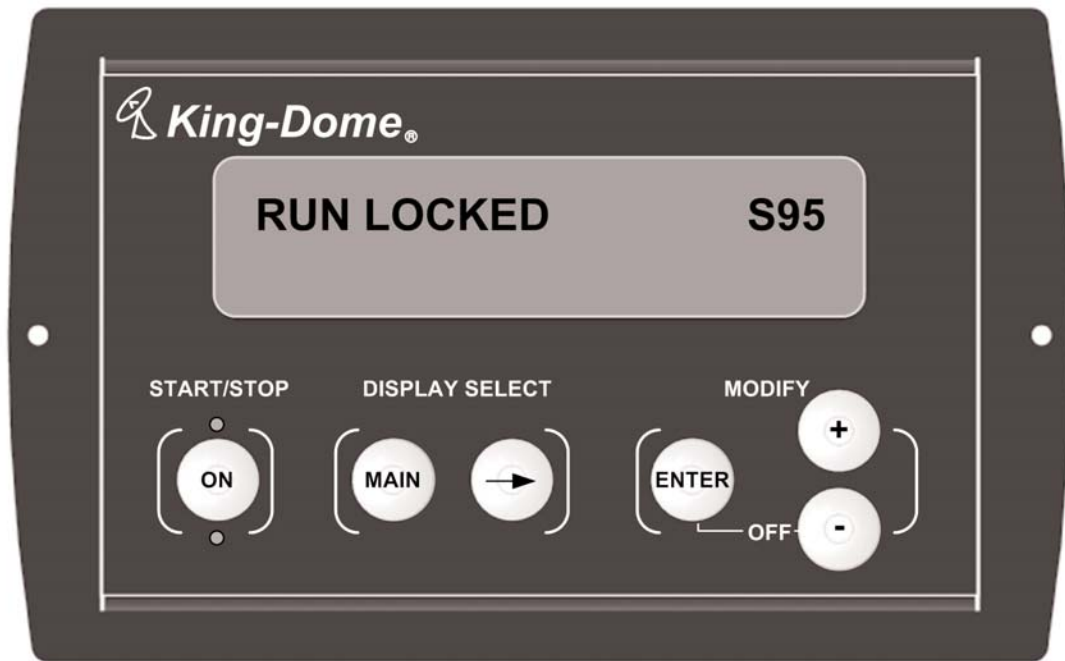

Trac-King In-Motion Satellite System

9762-LP

Installation and Operating Instructions



Satellite Solutions for Mobile Markets

11200 Hampshire Avenue South, Bloomington, MN 55438-2453
Phone: (800) 982-9920 Fax: (952) 922-8424

www.kingcontrols.com

IMPORTANT!

The satellite TV market is expanding and changing. The information in this manual was accurate at the time of printing. If your King-Dome does not operate as outlined in this manual please call King Controls at (800) 982-9920 or visit our website at www.kingcontrols.com.

TABLE OF CONTENTS

Section	Contents	Page
1.	INTRODUCTION.....	2
2.	DEFINITION OF TERMS	3
3.	INSTALLATION	4-17
4.	OPERATION	18-21
5.	TROUBLESHOOTING	22-26
6.	MAINTENANCE	27
7.	LIMITED WARRANTY	28

ELECTRICAL HAZARD WARNING!

The coaxial cable that connects the dome unit to the tuner carries a 24 volt electrical current. Exercise extreme caution when handling this cable. Do not cut, break, or splice this line. Do not insert or connect any devices such as splitters or any other device for any reason. This line is not compatible with any other equipment. Damage will occur to any device other than the dome unit if connected to the antenna port on the tuner.

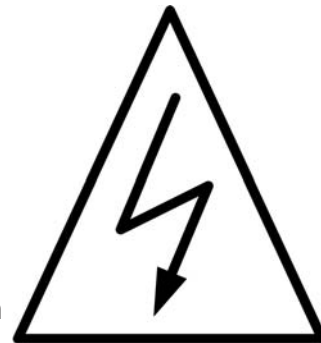

The Trac-King In-Motion Satellite System includes 4 main components (**Fig. 1**).

Dome (Antenna) Unit	Located on the roof of the vehicle. The dish is covered by a protective dome that keeps operational components free from the elements.
Controller	Located in the vehicle. Used to activate and monitor the system, and access programming and diagnostic information.
Tuner	Located in the vehicle. Decodes the satellite signal so the Trac-King locks onto and tracks the correct satellite.
Power Supply	Located in the vehicle. Supplies proper operating voltage to the Trac-King.

Note: A TV, satellite receiver, and program subscription are also required for satellite TV viewing (not supplied by King Controls).

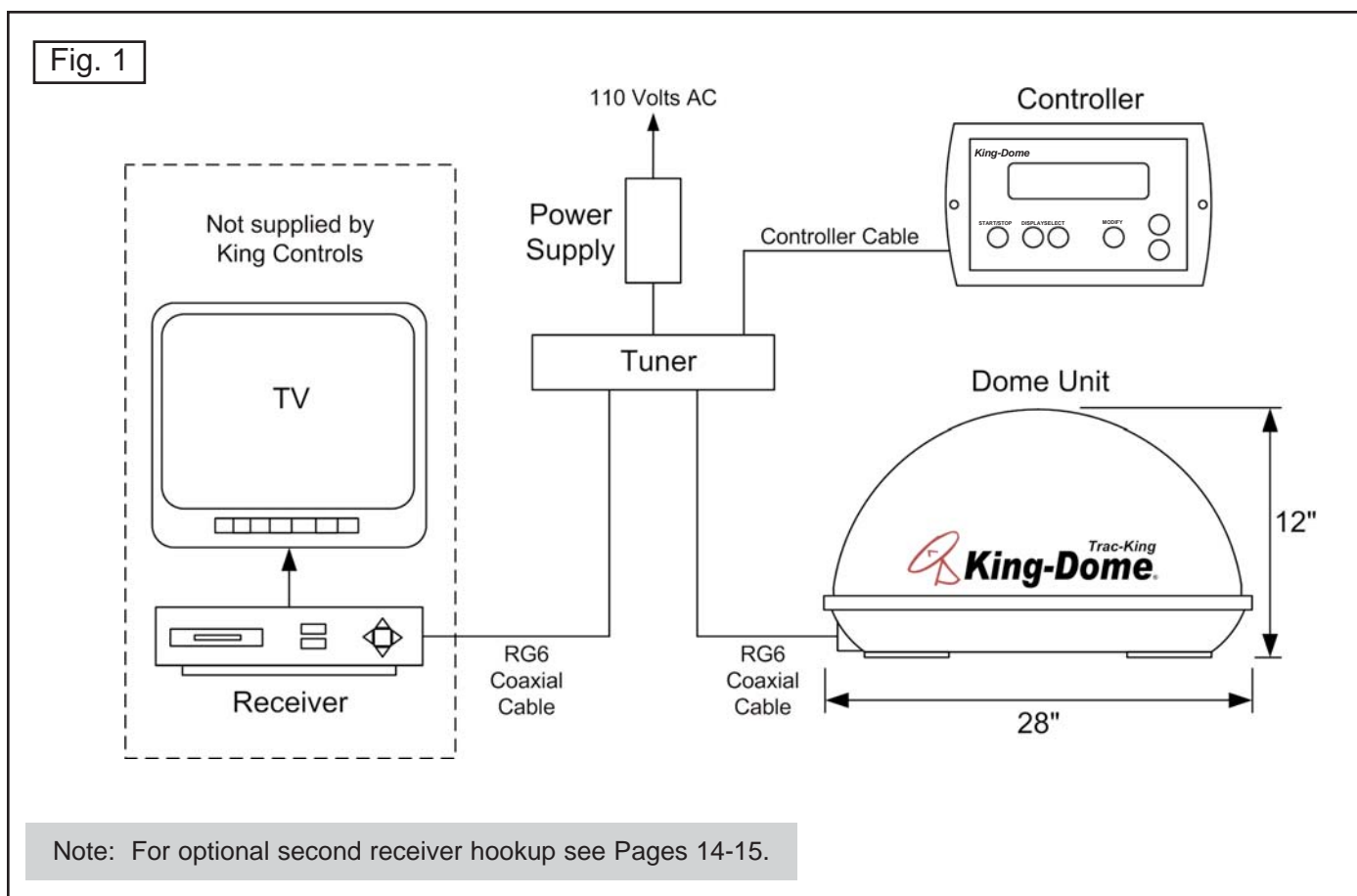

AZIMUTH: Angle in degrees measured clockwise from Magnetic North (0°) (Fig. 2).

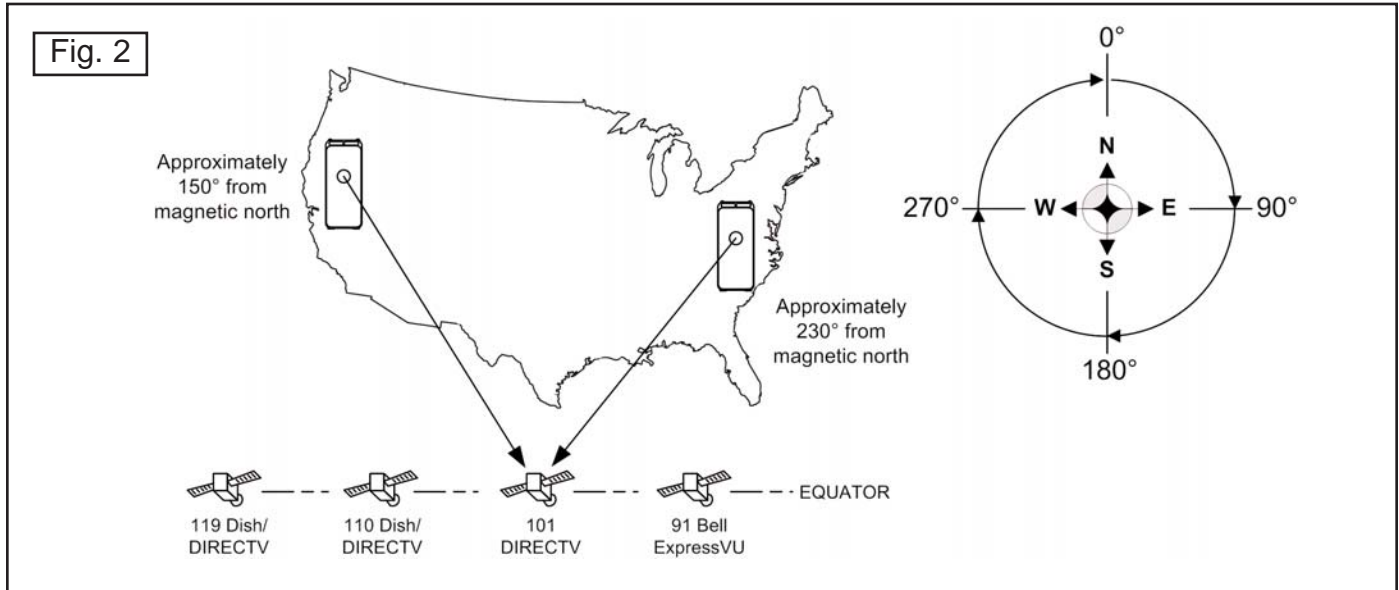

ELEVATION: Angle in degrees measured from the ground plane (Fig. 3).

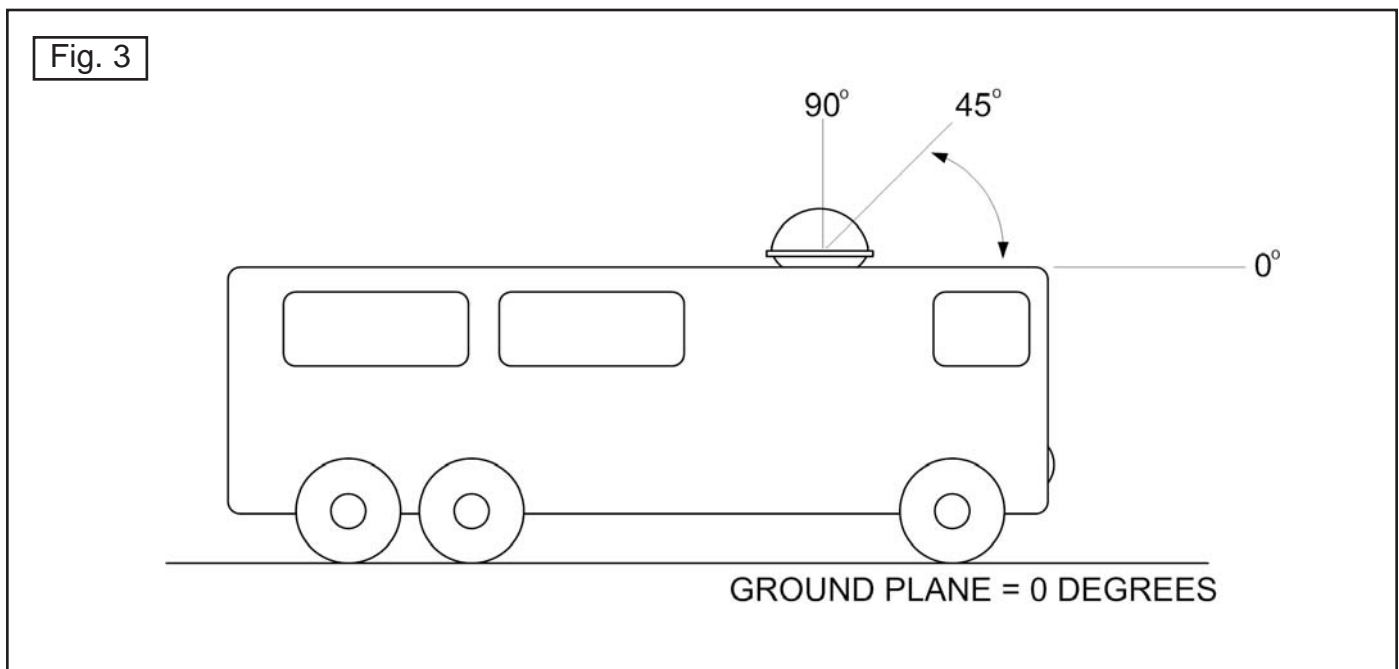

SIGNAL STRENGTH: Intensity of electronic signal received from the satellite transmission.

TOOLS AND MATERIALS REQUIRED:

- drill and drill bit set
- tape measure
- 7/16" open end wrench (coax connections)
- adhesive sealant (compatible with roof material)
- appropriate fasteners to install all components and wiring
- 5/32" allen wrench, channel lock or pliers (to remove shipping bolt)
- wire cutter (to remove shipping tie strap)

KIT CONTENTS:

1. Unpack and identify all components (**Fig. 4**).

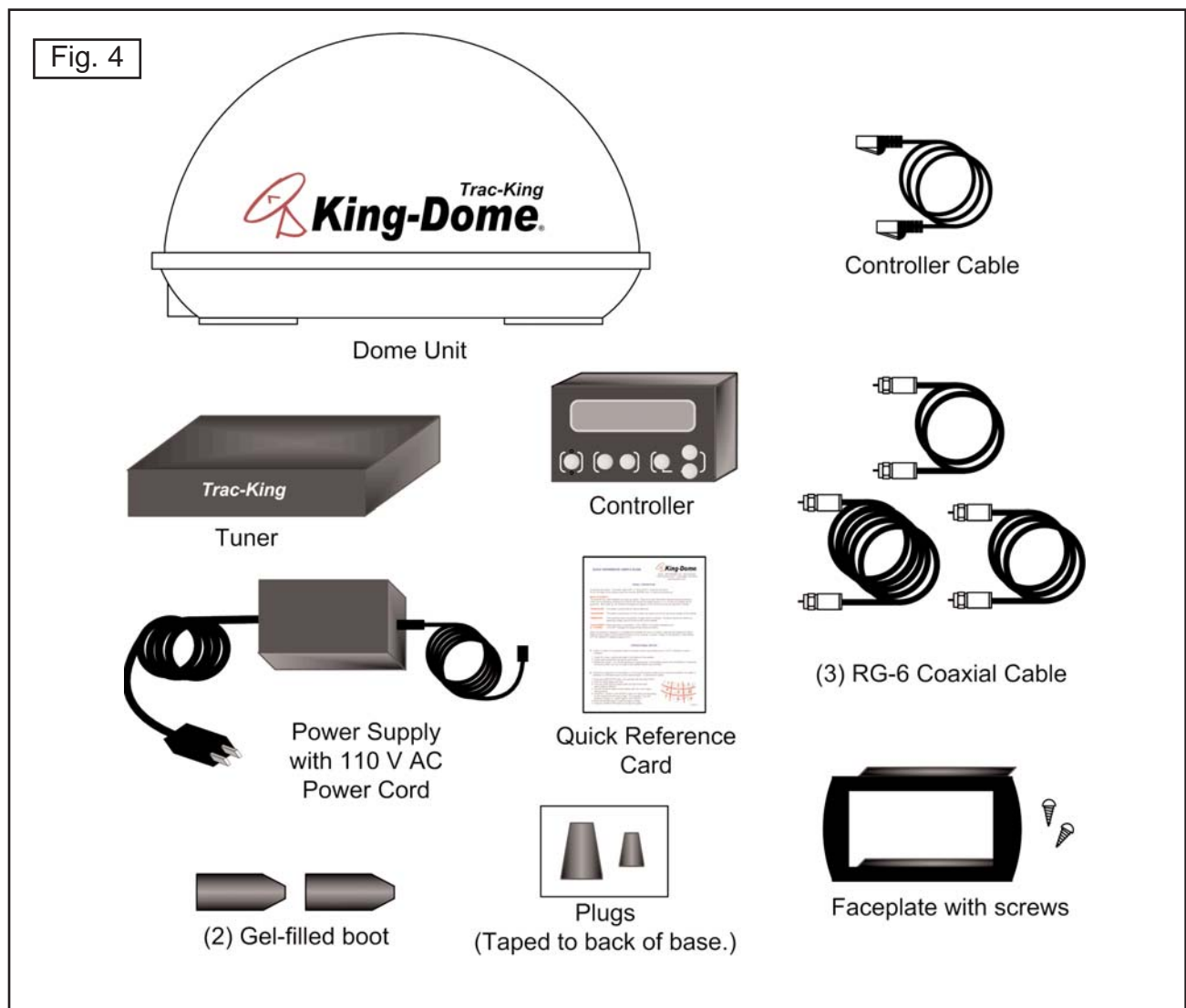

IMPORTANT! The tie strap and spacer, and the bolt and washer must be removed from the bottom of the dome unit prior to installation. **DO NOT REMOVE THE DOME COVER TO REMOVE THESE SHIPPING RESTRAINTS.**

YOU MUST PLUG THE TWO HOLES WITH THE SUPPLIED PLUGS. (TAPED TO BACK OF BASE.)

2. Remove and discard the tie strap and spacer, and the bolt and washer that pass through the bottom of the base (**Fig. 5**).

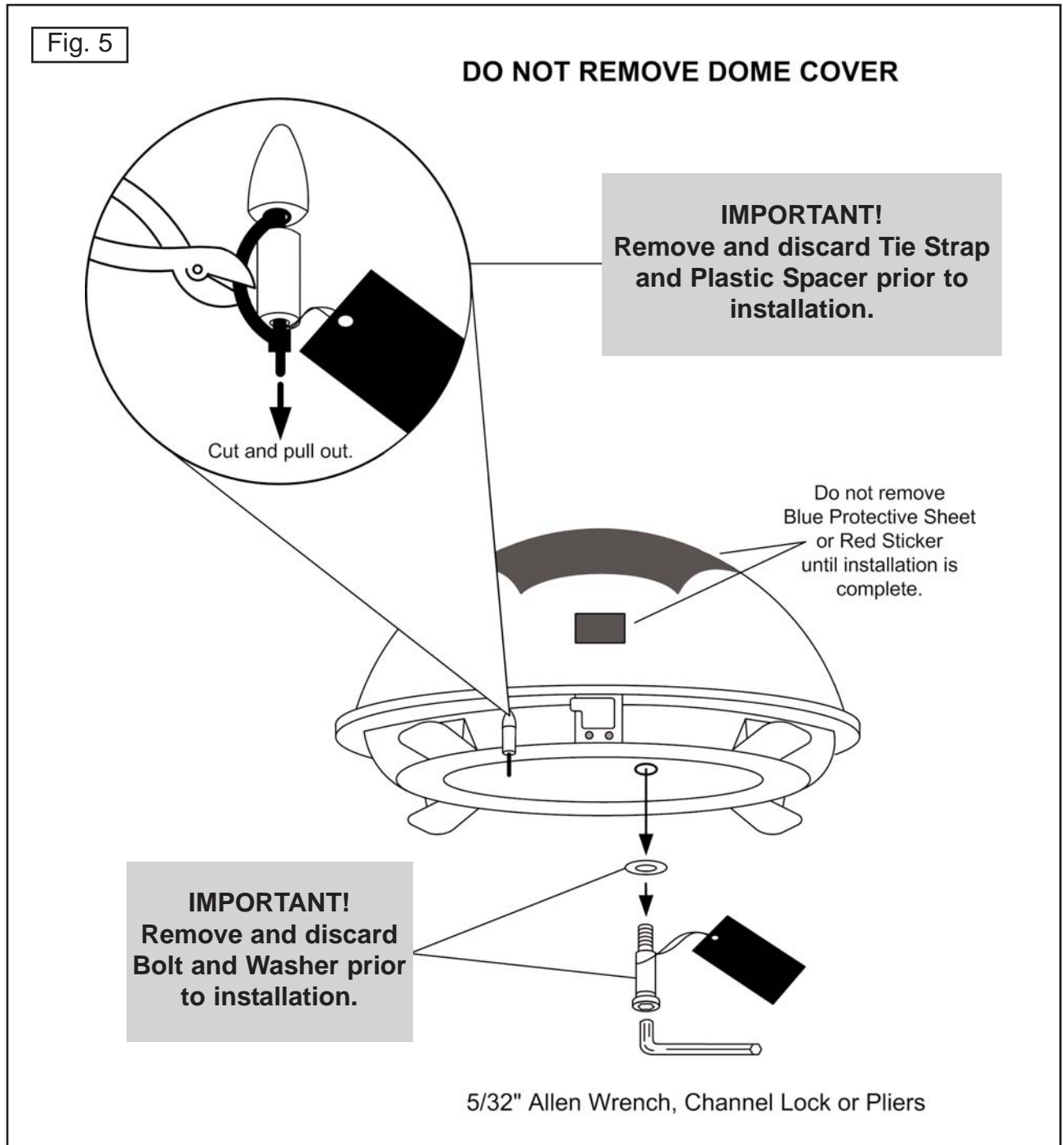

3. Insert provided plugs (taped to back of base) into holes that were occupied by tie strap and shipping bolt. Inserted plugs should be flush with base (**Fig. 6**).

Fig. 6

IMPORTANT!
After removing shipping restraints, firmly insert plugs into appropriate holes. Plugs should be flush with base.

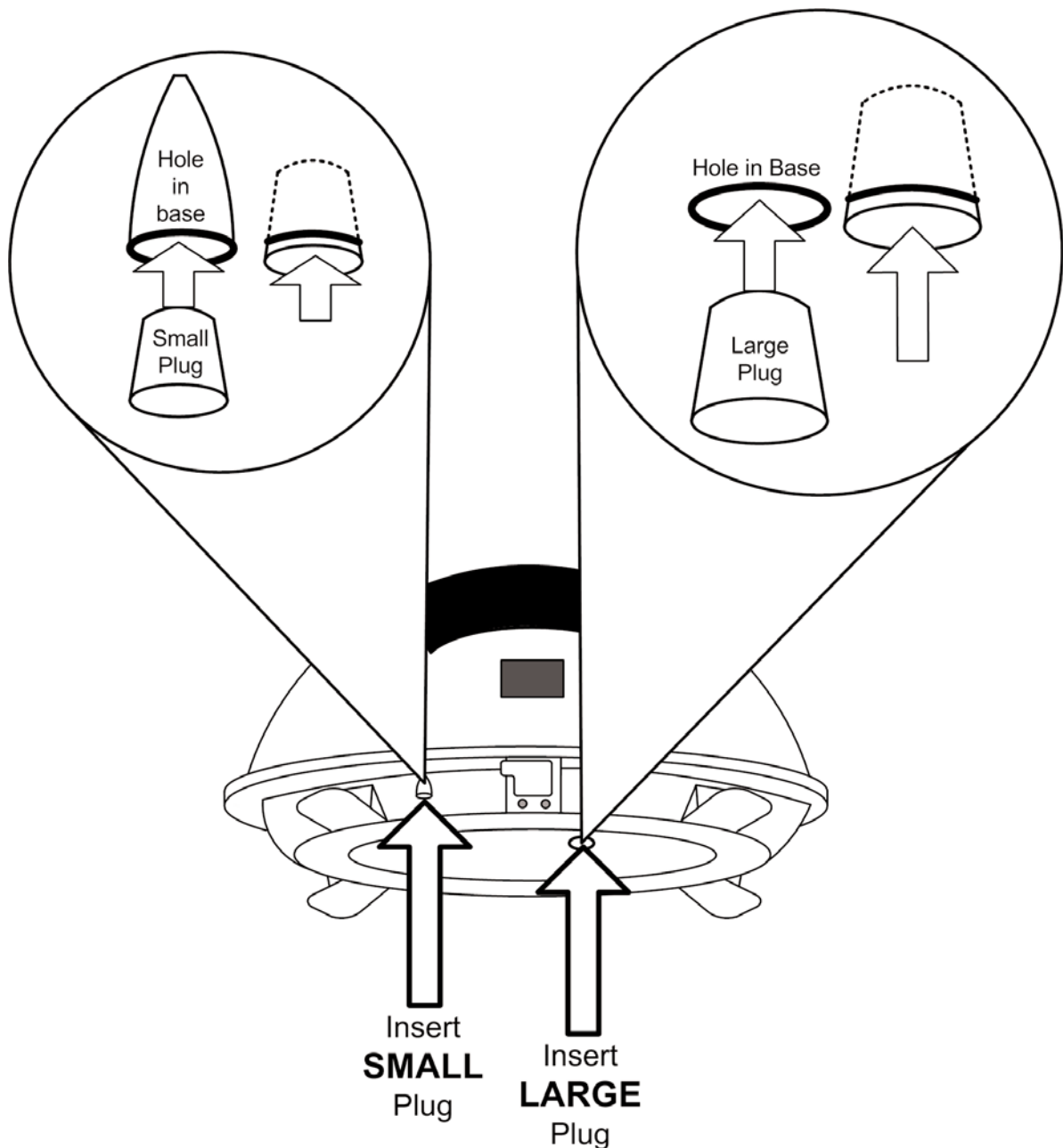

DOME LOCATION

1. Select an area on the roof for the dome unit and the location where the coax cables will enter the vehicle through the roof to the satellite receivers and internal components. Use the following criteria:
 - a) The shortest distance between the dome unit and the main satellite receiver is most desirable.
 - b) The dome unit requires a 28 inch diameter circle.
 - c) The dome unit should be mounted on the centerline of the vehicle (side to side).
 - d) There must be no "line of sight" obstructions from this location. Air conditioning units, other antennas, and storage areas that are too close to the dome unit may prevent the satellite signal from reaching the dish (**Fig. 7**).

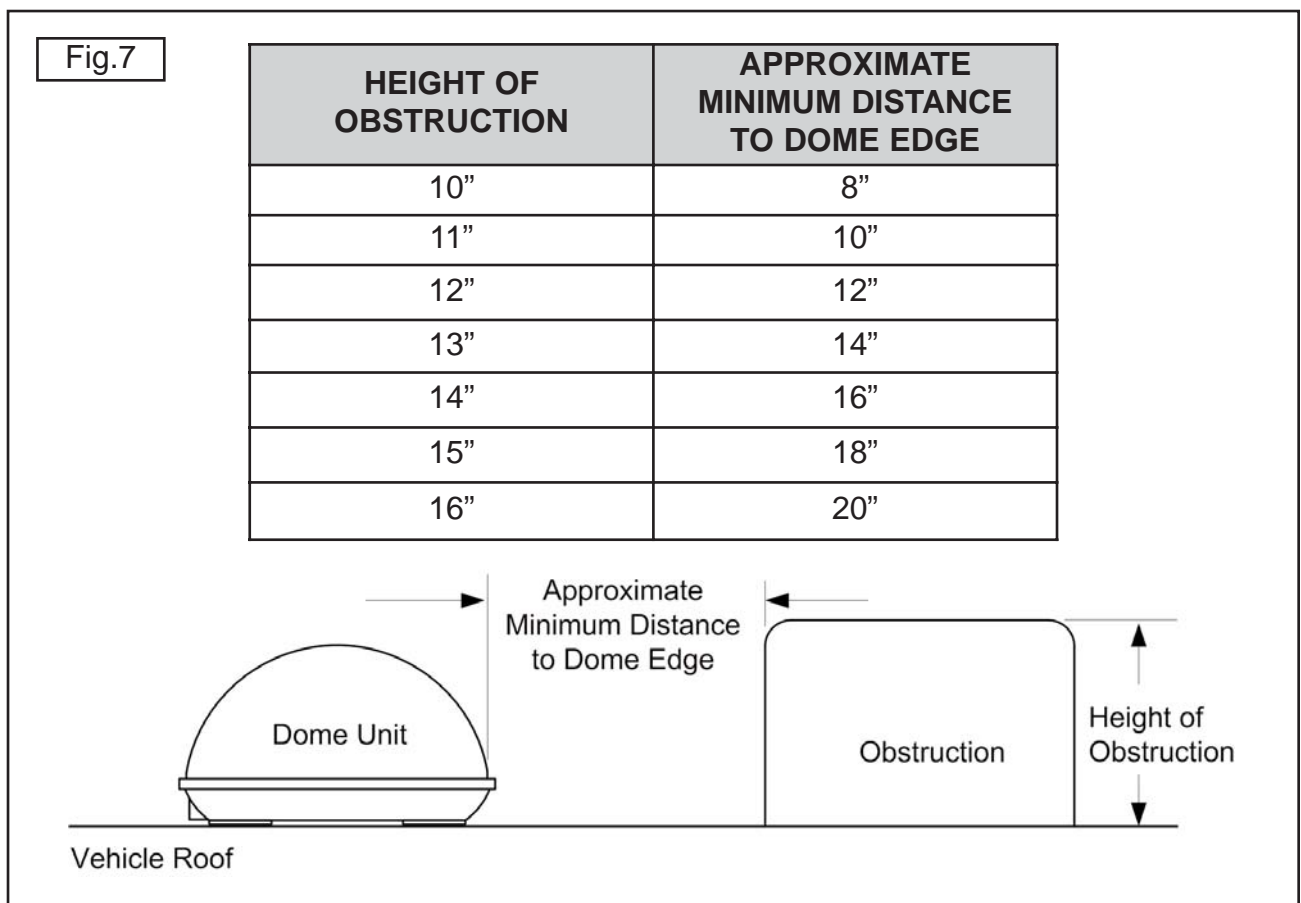

IMPORTANT! Make sure shipping restraints are removed from bottom of dome unit and plugs inserted in holes (Fig. 5, Page 5 and Fig. 6, Page 6).

Cable connections must **ALWAYS** be positioned facing rear of vehicle.

2. Place dome unit in selected area.

3. The dome unit must be positioned so that both feet on each side of the vehicle are equal distances from the roof edge. This should be checked by measuring the distance from each foot to the roof edge. Confirm that these measurements are equal (**Fig. 8**).

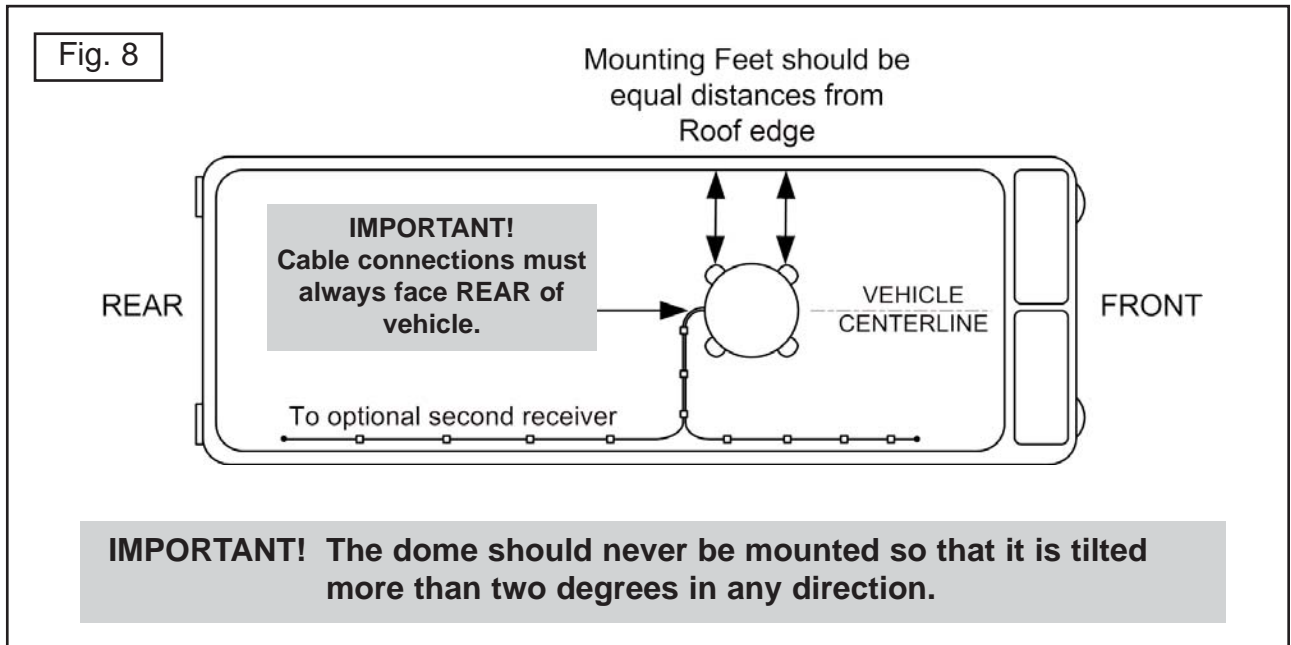

IMPORTANT! For installations on trucks with air shields, a bracket must be used for mounting the dome unit. The dome unit **MUST** be mounted to the air ride cab: **NEVER** to any structure mounted directly to the frame.

See bracket instructions for proper installation (**Fig. 9**).

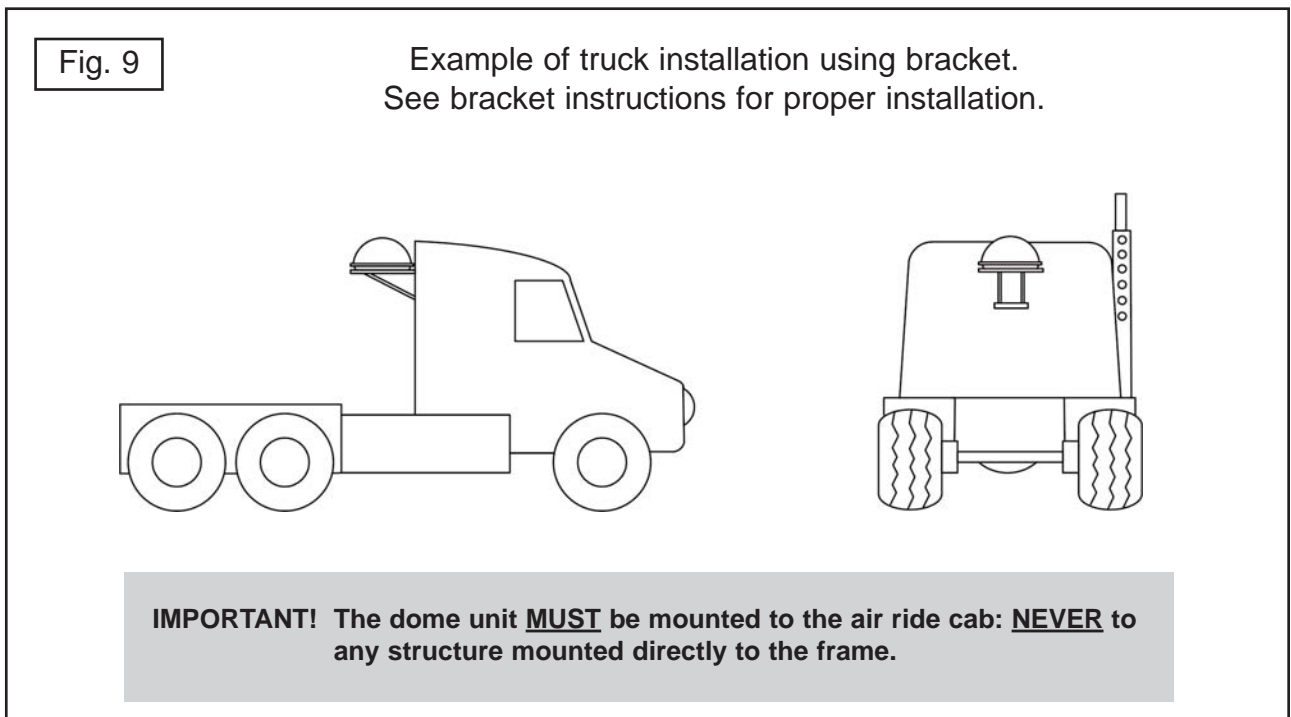

COMPONENT LOCATION

1. Determine the location of the internal components using the following criteria:
 - a) The Controller, Tuner, and Power Supply should be in the same general vicinity of the main satellite receiver, and **ACCESSIBLE FOR OPERATION AND MAINTENANCE PURPOSES.**
 - b) The Tuner should not be stacked directly on top of other electronics. If located in a cabinet or other enclosure, make sure there is adequate ventilation around the unit.
 - c) The Controller should be conveniently located for the end user. (If using the Wall Mount Faceplate, see page 16.)
 - d) All components should be secured so they do not shift or bounce around during vehicle motion.
2. Place the components in the selected areas.

SYSTEM LOCATION CHECK

ELECTRICAL HAZARD WARNING!

The coaxial cable that connects the dome unit to the tuner carries a 24 volt electrical current. Exercise extreme caution when handling this cable. Do not cut, break, or splice this line. Do not insert or connect any devices such as splitters or any other device for any reason. This line is not compatible with any other equipment. Damage will occur to any device other than the dome unit if connected to the antenna port on the tuner.

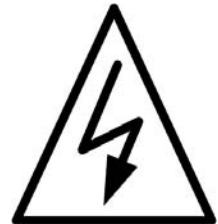

AVOID SHARP BENDS WHEN ROUTING COAX!

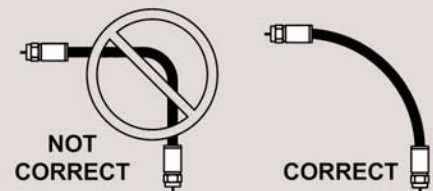

To verify proper operation of the components in their selected locations, perform a System Location Check as follows:

1. **TEMPORARILY** connect system as outlined in **Fig. 13, Page 15.**
2. Verify system operates properly as described in **Section 4 OPERATION, Page 18.**
3. After verifying system operates properly, disconnect all components.

DOME INSTALLATION AND EXTERNAL WIRING

IMPORTANT! Use only the coaxial cables supplied with the Trac-King. Do not cut coax. Coil and store excess cable in the cabinet with the components.

If coaxial cable other than that supplied with the Trac-King is used, the following guide lines must be followed:

- 1) Ends must be terminated with SNAP-N-SEAL® connectors or radial F-connectors as shown in Fig. 10. **(DO NOT USE TWIST-ON CONNECTORS.)**
- 2) Cable must be RG-6 or better, and rated at 2.2 Ghz or higher.

Fig. 10

IMPORTANT!
Use
factory recommended
stripper only.



Fold wire braiding back.

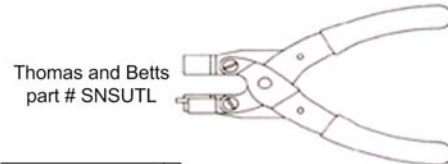
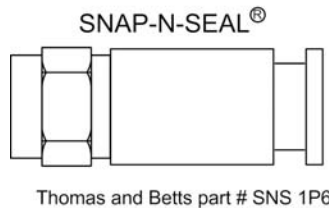
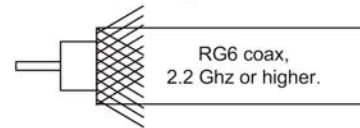

IMPORTANT!
Rubber O-rings must be
REMOVED from ends of all
SNAP-N-SEAL® connectors
and radial F-connectors.

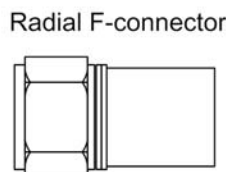

IMPORTANT!
COMPRESSION STYLE CRIMPER ONLY!
(Do not use hex style.)

1/16" Min. to 1/8" Max.

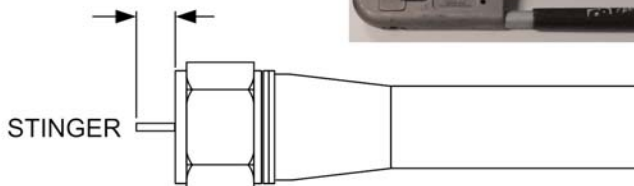

Note: The installer is responsible for determining the most appropriate fastener to secure the dome unit to the roof. Depending on the roof material, fasteners such as lag screws, well nuts, sheet metal screws, toggle bolts and T anchors may be used, and should always be used in combination with a roof compatible sealant.

IMPORTANT! The installer is responsible for weatherproofing all holes with sealant.

IMPORTANT! Make sure power supply is disconnected from 110 volt source before continuing with permanent installation.

Make sure shipping restraints are removed from bottom of dome unit, and plugs inserted in appropriate holes (Fig. 5, Page 5 and Fig. 6, Page 6).

Cable connections must ALWAYS be positioned facing the rear of vehicle.

1. Mount the dome unit. Use the pre-drilled holes in the mounting feet as a guide to install the fasteners into the roof. Use additional fasteners whenever necessary.
2. Test that the dome unit is secure by pulling upward from each foot location.

Note. The King-Dome is wired for a dual LNB. There are two coaxial ports on the back of the dome unit. The one labeled "MAIN" **MUST** be connected to the Tuner (IDB) in vehicle. The one labeled "AUX" can be used for an additional receiver (see page 15).

There are three lengths of coaxial cable supplied. The 7' is used to connect the tuner to the receiver. The longer two are for connecting the dome unit to the receivers. Use the shorter of the two for the closest receiver, and the longer one for the receiver farthest away.

It is recommended that non-conductive electrolytic grease be applied to all stingers (coax cable center conductors) before installation.

IMPORTANT! Do not remove the rubber sleeve from the coax port. The coax cable end will slide inside the sleeve as it is tightened.

3. Connect coax cable to the coax port labeled MAIN on the back of the dome unit and tighten connection. If using a second receiver, connect second coax cable to coax port labeled AUX and tighten connection. **DO NOT OVER TIGHTEN CONNECTIONS (Fig. 11).**
4. Snap the gel-filled boot(s) around the coax cable(s), and push flush against the rubber sleeve(s) on the coax port(s) **(Fig. 11).**

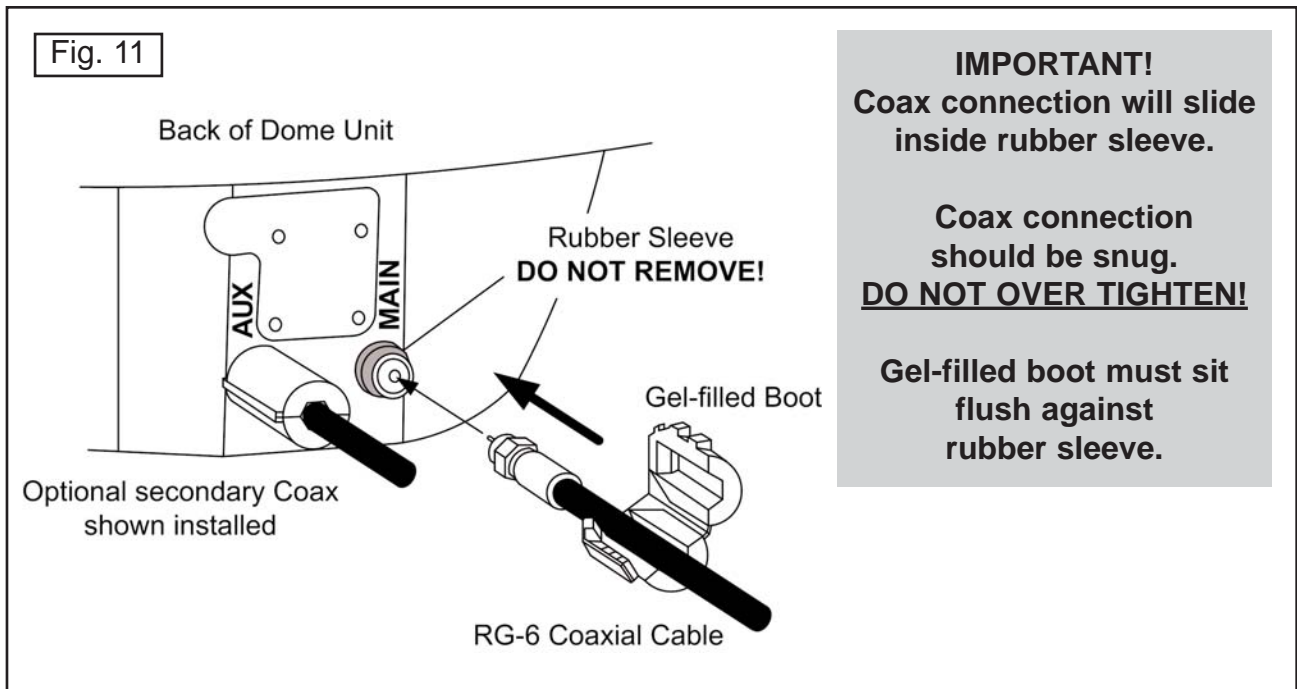

AVOID SHARP BENDS WHEN ROUTING COAX!

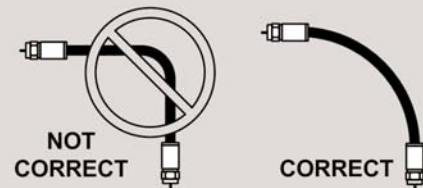

- Run coax from the dome unit to the roof edge, then along edge to location where coax will be fed into the vehicle. Secure coax to roof every 12-18 inches. (If installing an optional second receiver, run auxiliary coax to location where it will enter the vehicle.) Secure wiring to roof every 12-18 inches (**Fig. 12**).
- Drill 3/4" hole through the roof and into the cabinet where main receiver is stored. Feed coax down through hole. Seal opening with roof compatible sealant so that it is entirely waterproof (inside and outside of the 3/4" hole). Repeat for optional second receiver. (**Fig. 12**).

Fig. 12

TYPICAL ROOF INSTALLATION - OVERHEAD VIEW

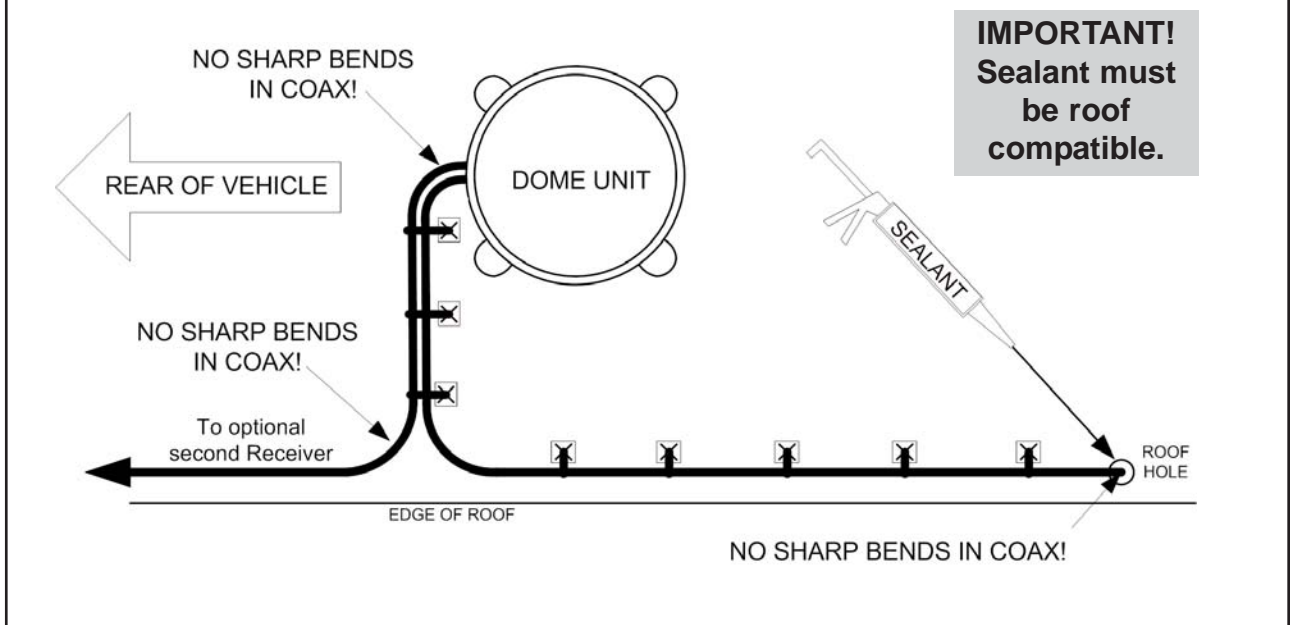

7. Remove blue protective sheet and red "position to rear" sticker from the dome unit.

ELECTRICAL HAZARD WARNING!

The coaxial cable that connects the dome unit to the tuner carries a 24 volt electrical current. Exercise extreme caution when handling this cable. Do not cut, break, or splice this line. Do not insert or connect any devices such as splitters or any other device for any reason. This line is not compatible with any other equipment. Damage will occur to any device other than the dome unit if connected to the antenna port on the tuner.

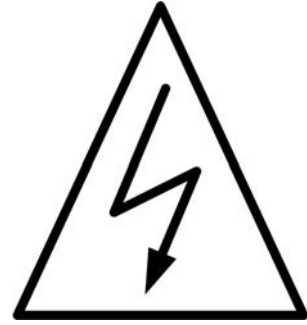

INTERNAL WIRING:

IMPORTANT! The coax cable from the “MAIN” port on the dome unit MUST be connected to the Tuner (IDB) in the vehicle.

Coax connections should be snug. DO NOT OVER TIGHTEN.

1. Connect coax cable from “MAIN” on dome unit to the tuner port labeled “ANT.”
2. Connect the 7’ coax from tuner port labeled “REC” to the main satellite receiver port labeled “SATELLITE IN.”
3. Connect the 7’ controller cable from the controller to the tuner port labeled “IDD.”
4. If installing a second receiver, connect coax cable from “AUX” on dome unit to the “SATELLITE IN” port on the second receiver.

Note: Make sure the proper connections are made between the receivers and TVs.

IMPORTANT! When connecting the power supply cable to the tuner, push in the power supply cable end until it is flush against the back of the tuner.

5. Connect the power supply cable to the tuner port labeled “PWR”.
6. Plug the power supply into a 110 VAC source.

Note: The controller should turn on for 3 seconds and then turn off. If the controller stays on, press the ENTER and “-” buttons simultaneously for 3 seconds to turn unit off.

Fig. 13

9762-LP DUAL LNB WIRING DIAGRAM

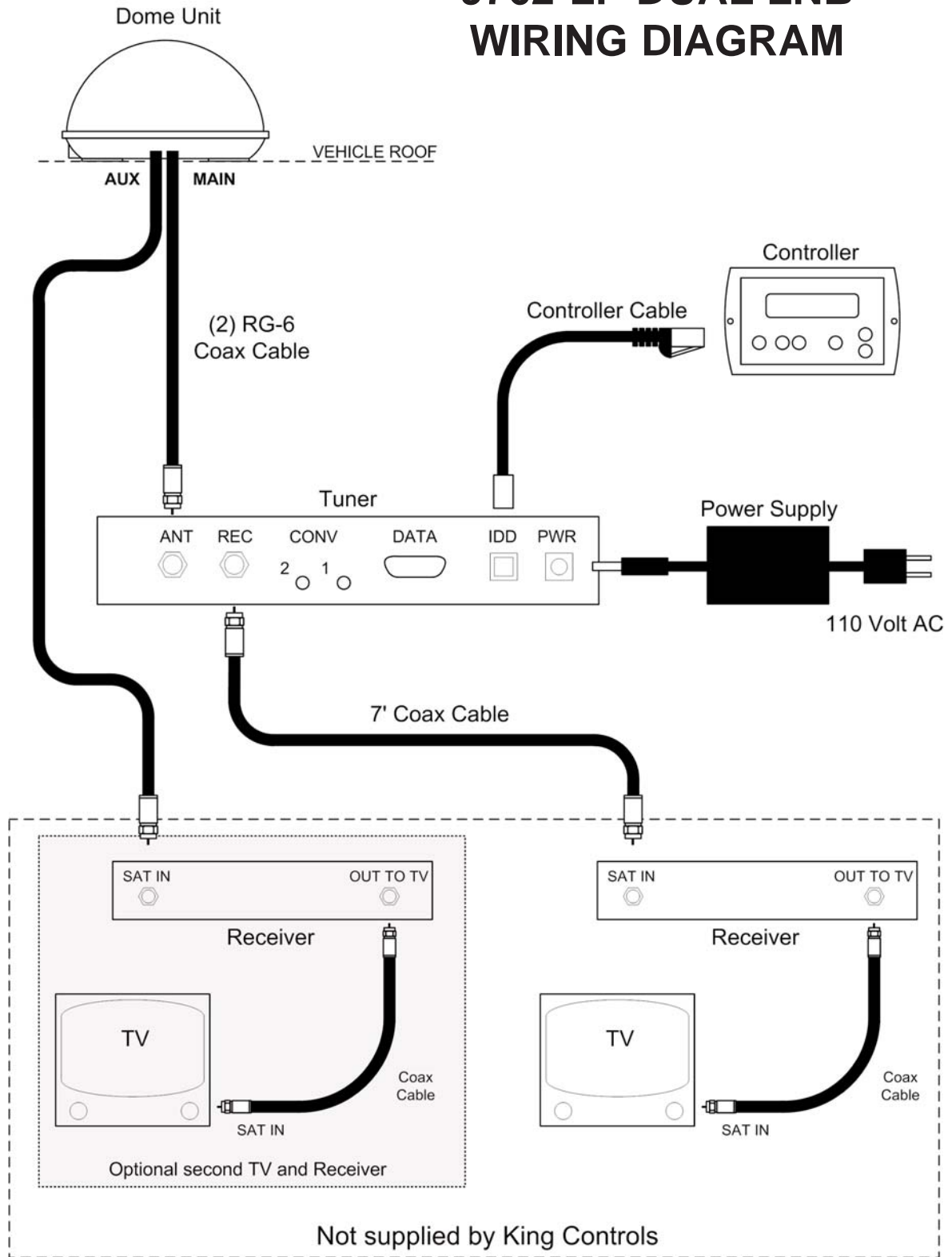

IMPORTANT! AVOID SHARP BENDS WHEN ROUTING COAX.

WALL MOUNT FACE PLATE #101029

Note: The Wall Mount Faceplate does not have to be installed.

1. Use the Faceplate as a guide to mark and cut out the mounting cavity, and if necessary, mark and drill the mounting holes (**Fig. 15**).

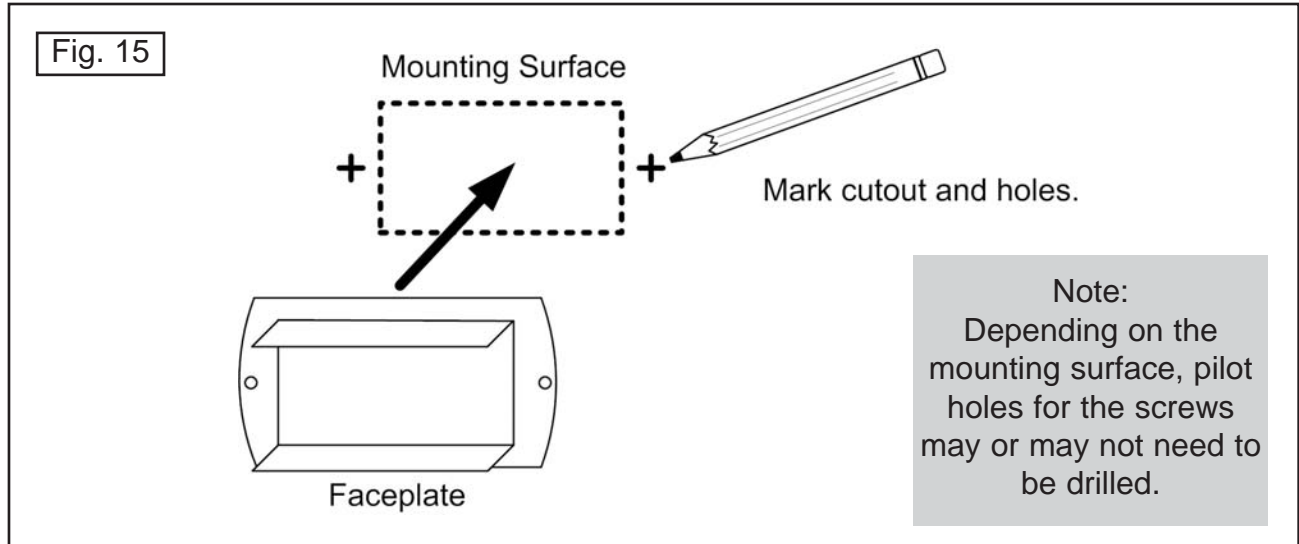

2. Remove 4 screws from Controller (**Fig. 16**).
3. Slide Faceplate over Controller.
4. Replace 4 screws.
5. Mount Faceplate in wall with supplied screws.

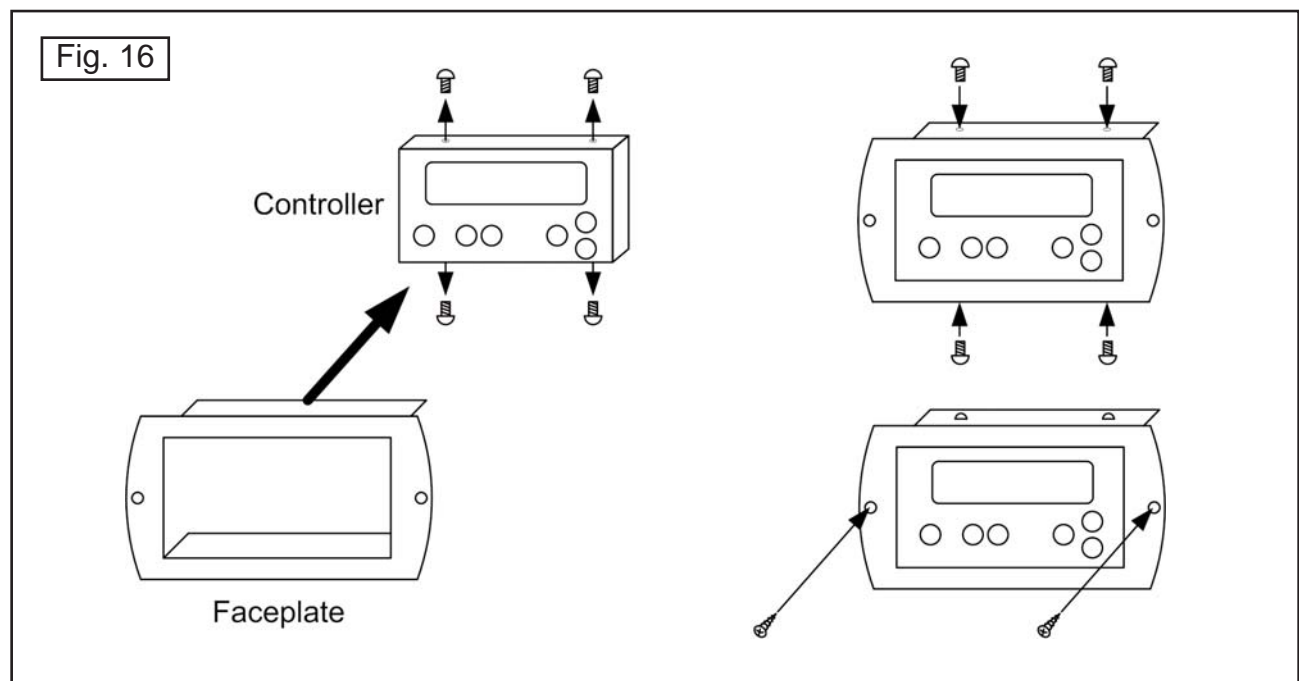

This page intentionally left blank.

SECTION 4 OPERATION

IMPORTANT! There must be a clear “line of sight” to the satellite (See Fig. 2, Page 3). Mountains, buildings, trees, telephone poles, etc. can all block the satellite signal from reaching the dish.

Note: This example is for the DTV 101 satellite in Region 2-North Central. The information on your controller will vary depending on the satellite and region you have chosen.

1. Turn on TV and satellite receiver. “Searching for Satellite Signal” or similar should appear on TV.

2. Press 



Unit powers up, performs a self-diagnostic and loads software.

Unit begins searching for the selected satellite.

Unit has locked onto the selected satellite.

**POWER UP
PLEASE WAIT**

**LOADING
PLEASE WAIT**

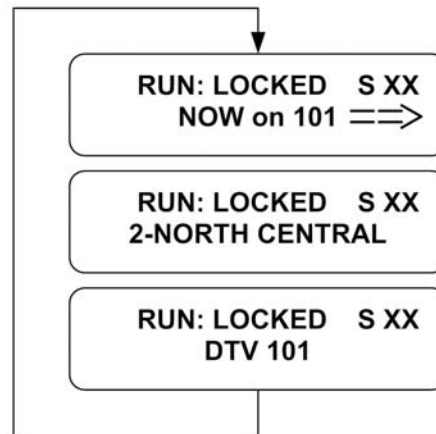
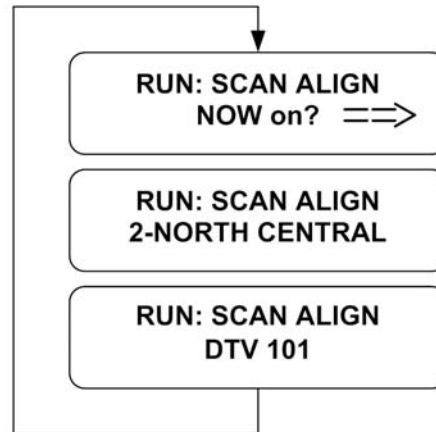

Note: The Trac-King must remain powered on to maintain a signal. If you are going to be stationary and wish to continue watching TV, **DO NOT TURN THE SYSTEM OFF.**

Note: To reduce satellite acquisition time, you can set your current region.

SET REGION (OPTIONAL)

1. Press  Unit goes into IDLE/HOLD mode.

IDLE/HOLD SXX
NOW on 101 ==>





2. Press  Unit goes into USER SETUP menu.

USER SETUP ==>
Rev xxxx sn xxxxx

3. Press  Unit goes into SET REGION menu.

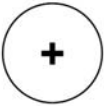
SET REGION
■■■■■■■■

4. Press 
or  Find your location on the map below and determine which region you are in. Use the plus and minus buttons to display your region on the controller.

Display your region on
the controller.

5. Press  Sets REGION into memory.

IDLE/HOLD SXX
NOW on 101 ==>

6. Press  Unit searches based on new REGION.

RUN: SCAN ALIGN
DTV 101

REGION OPTIONS:

- 1 NORTH WEST
- 2 NORTH CENTRAL
- 3 NORTH EAST
- 4 CENTRAL WEST
- 5 MIDDLE CENTRAL
- 6 CENTRAL EAST
- 7 SOUTH WEST
- 8 SOUTH CENTRAL
- 9 SOUTH EAST
- ALL REGIONS
- 0 RECALIBRATE

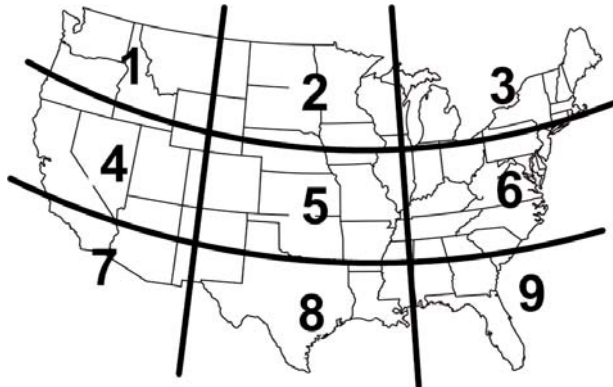

SET SATELLITE SERVICE

SATELLITE OPTIONS

DTV 101	DIRECTV at 101 West Longitude
EXPVU 82	Bell ExpressVu at 82
Dish 148	Dish Network at 148
EXPVU 91	Bell ExpressVu at 91
Dish 61	Dish Network at 61
DTV 101/119	DIRECTV at 101 and 119
DTV 101/110 HD	DIRECTV at 101 and 110 (High Definition)
SAT 119	Dish Network at 119
SAT 110	Dish Network at 110

Note: Future locations can be added.



Unit goes into SET SATELLITE menu.

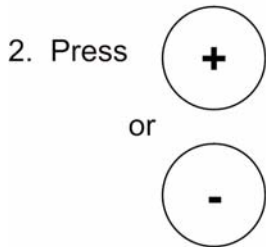

Use the plus and minus buttons to display your selected satellite on the controller.



Sets satellite in memory. Unit moves to new selected satellite.

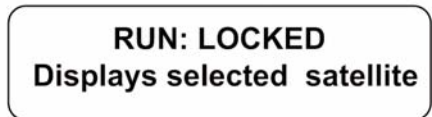
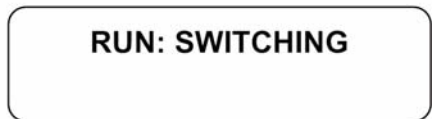

Note: **For DIRECTV® Subscribers:** The satellite setting allows the user to select the satellite and service provider of choice. For DIRECTV subscribers, the Trac-King can also track a secondary or alternate satellite.

Example: If you are a subscriber to the DIRECTV service most of the programming that you will be watching will be transmitted from the satellite located at 101 degrees. You may also subscribe to programming that is transmitted from another satellite located at 119 degrees. In order to receive programming from both satellites you can either select an individual (DTV 101) satellite manually from the display or you can select a multiple (DTV 101/119) satellite setup. The multiple satellite selection will automatically switch between satellites (DTV 101/119) based on the channel or programming that you select on the Satellite Receiver (multi-satellite capable receiver is required). Please keep in mind that the programming may pause (freeze frame) or pixelate while the antenna acquires and locks onto the new satellite.

The multiple satellite setting will work only if your satellite receiver is set up to work in oval dish mode. Consult your satellite receiver manual for instructions.

It is not recommended to use the DTV 101/119 setting unless there is programming on the DTV 119 satellite that you specifically subscribe to.

For Dish Network® Subscribers: Use the procedure on the previous page to switch between the 110 and 119 satellites.

SYMPTOM	POSSIBLE SOLUTION
Controller does not power up.	Check: tuner is connected to power supply. controller is connected to tuner. power supply is plugged into 110 VAC outlet.
Controller remains in "Power Up, Please Wait" condition.	Disconnect power supply for 15 seconds, then reconnect. Verify voltage on coax at dome unit is 24 volts. Inspect rotary joint cable, then reseal (inside dome unit). Inspect all coax cables and verify connections are snug but not overly tight (inside and outside dome unit).
Controller displays "Load Error".	Disconnect power supply for 15 seconds, then reconnect. Inspect rotary joint cable, then reseal (inside dome unit).
Controller displays "AZ FAULT" Dish cannot rotate.	Verify shipping bolt is removed (see page 5). Disconnect power supply for 15 seconds, then reconnect. Perform MECHANICAL CALIBRATION (page 26). Perform OPTION 21 RE-INITIALIZE and 0-RECALIBRATE (pages 24-25). Reseat ribbon cables (inside dome unit).
Controller displays "EL FAULT"	Make sure shipping tie strap is removed (see page 5). Disconnect power supply for 15 seconds, then reconnect. Perform MECHANICAL CALIBRATION (page 26). Restart system. If problem persists, perform OPTION 21 RE-INITIALIZE and 0-RECALIBRATE (pages 24-25). Reseat ribbon cables inside dome unit.

SYMPTOM	POSSIBLE SOLUTION
<p>Only getting signal on 1/2 of transponders.</p>	<p>Kinked or sharply bent coax cable.</p> <p>Verify coax cables are tightly crimped with RADIAL (COMPRESSION) style crimps only.</p> <p>Verify receiver is operating properly.</p> <p>Verify LNB type is set correctly.</p>
<p>Unit never locks on or locks on and drifts off of satellite.</p>	<p>Atmospheric moisture. Unit will lock on as weather improves.</p> <p>Check for obstruction in sky in direction of satellite. Select another satellite and verify unit locks on.</p> <p>Verify coax cables are tightly crimped with RADIAL (COMPRESSION) style crimps only.</p> <p>Perform OPTION 21 RE-INITIALIZE and 0-RECALIBRATE (pages 24-25).</p> <p>Inspect all coax cables and verify connections are snug but not overly tight (inside and outside dome unit).</p>

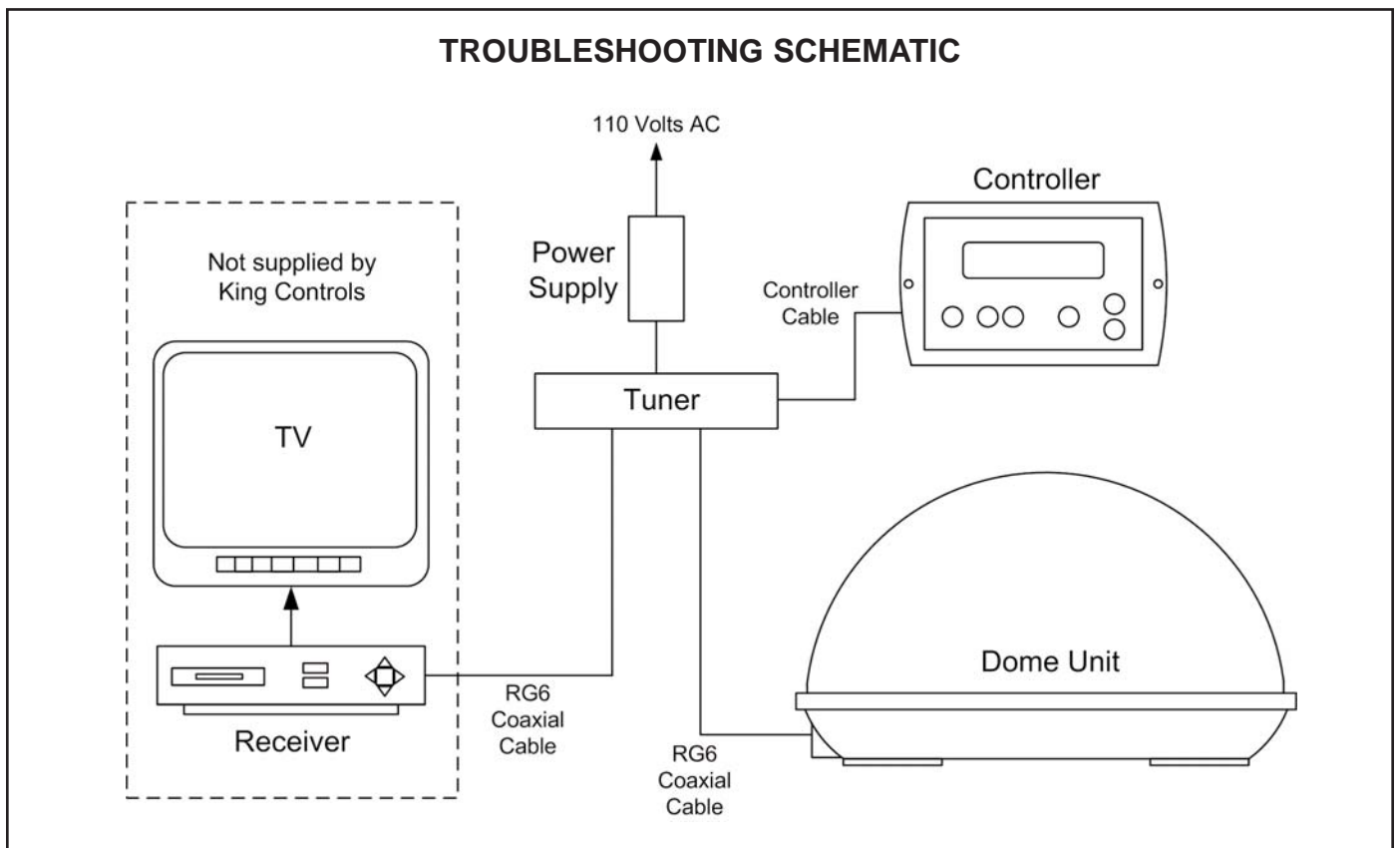

OPTION 21 RE-INITIALIZE and 0 RECALIBRATE

1. Press **MAIN** as needed
to enter DEALER SETUP menu.



DEALER SETUP ==>
CODE 0

2. Press **+** as needed to scroll up to CODE 13.

Press **ENTER**

DEALER SETUP ==>
CODE 13

3. Press **→** as needed to enter SET OPTION menu.

SET OPTION
OPTION 0

4. Press **-** as needed to scroll down to OPTION 21.

Press **ENTER** to re-initialize software.

SET OPTION
OPTION 21

LOADING
PLEASE WAIT

5. Wait until display shows OPTION 0.
(May take up to 30 seconds.)

Press **ENTER** and **-** simultaneously to shut
system off.

SET OPTION
OPTION 0

off

6. Disconnect power (110 volt power supply)
from tuner for 10 seconds, then reconnect.

WAIT 10 SECONDS!



7. Wait until controller shows "off" then press **ON** to
start system.

off

8. Wait for system to load.

**POWER UP
PLEASE WAIT**

**LOADING
PLEASE WAIT**

When display shows RUN: SCAN ALIGN,

press  to enter IDLE/HOLD mode.

**IDLE/HOLD SXX
NOW on ? ==>**

9. Press  to enter USER SETUP menu.

**USER SETUP ==>
Rev xxxx sn xxxxx**

10. Press  to enter SET REGION menu.

**SET REGION
■■■■■■■■**

11. Press  or  as needed to display 0-RECALIBRATE.

**SET REGION
0-RECALIBRATE**

12. Press  System recalibrates gyros.

**RUN: SCAN ALIGN
0-RECALIBRATE**

13. Press  to exit IDLE/HOLD mode.

RUN: SCAN ALIGN

System will continue to run during recalibration process. Recalibration is complete when 0-RECALIBRATE no longer scrolls across bottom of display with search information. May take up to 10 minutes.

14. System continues to run after recalibration is complete.

**RUN: SCAN ALIGN
DTV 101**

MECHANICAL CALIBRATION

IMPORTANT! The Trac-King must remain perfectly still during the mechanical calibration. Do not have the vehicle running during the process.

The Trac-King must be running. (NOT IN IDLE/HOLD)

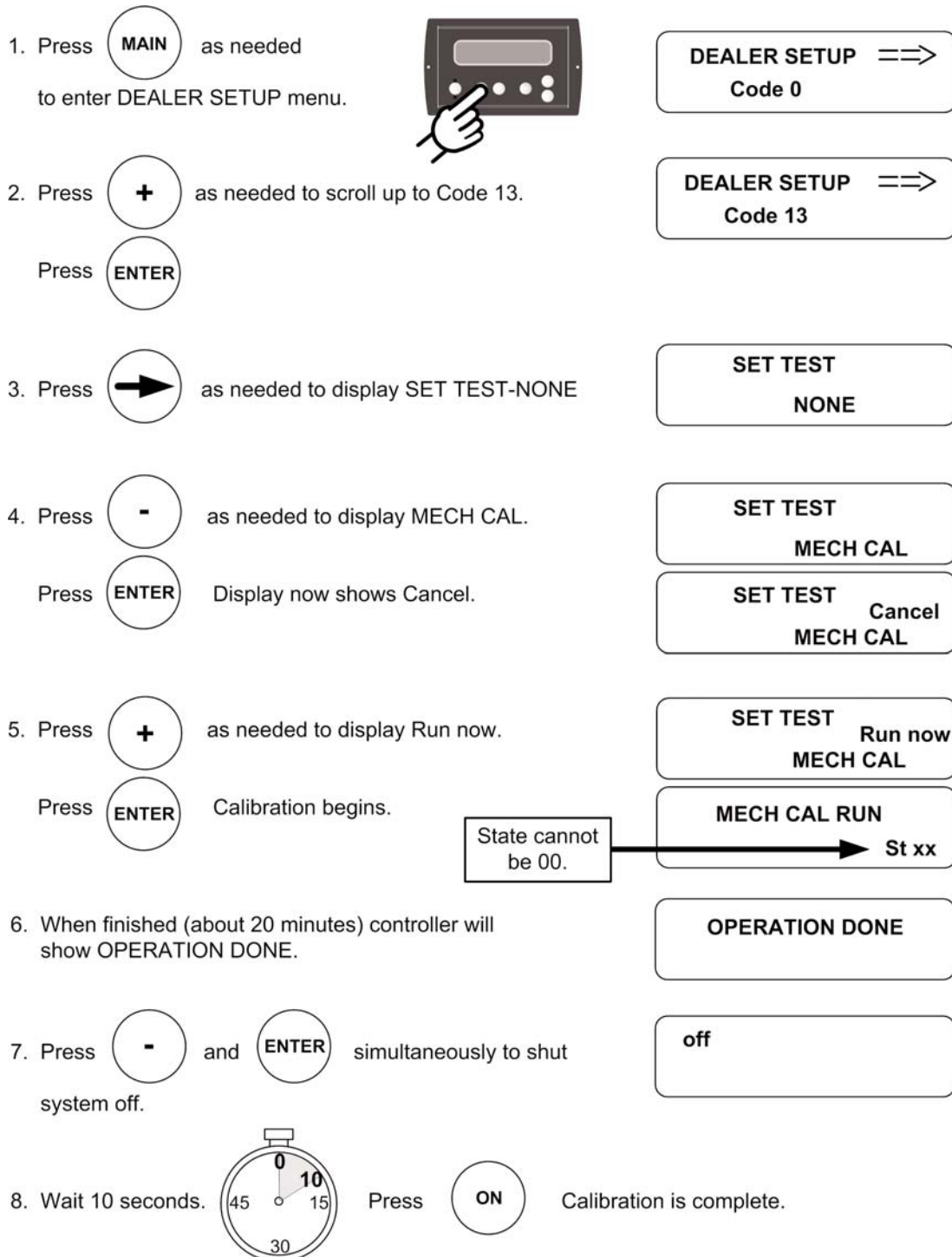

The King-Dome Satellite System has been designed to be maintenance and trouble free.

For optimum signal strength, keep the dome clean from dirt, bugs, and other debris. Periodic washing of the dome with mild soap and water is recommended.

If you plan on storing your vehicle for long periods of time, it is recommended that the system be put through a search procedure on a quarterly basis to keep all moving parts in good working order.

If you have any comments or questions, please contact the King Controls Service Department at (800) 982-9920, or email King Controls at info@kingcontrols.com

Rain Fade

Rain or dew on the dome can cause signal interference and make the digital picture freeze, pixelate or go out altogether. This loss of signal is commonly referred to as “rain fade” and is caused by the combination of water in the atmosphere and water on the dome surface.

To minimize this issue and eliminate the effects of water on the dome, apply King Controls’ **Dome Magic™** rain fade solution to the dome. This will prevent water from sticking to the dome surface and blocking the signal. For additional details on **Dome Magic™** rain fade solution please contact your authorized King-Dome dealer or call King Controls at (800) 982-9920.



Every King Controls Satellite System is thoroughly inspected and tested before leaving the factory. It is covered by a two year parts and one year labor limited warranty from the date of original purchase. This warranty does not cover installation and external wiring or refurbished units.

Should any trouble develop during the warranty period, contact King Controls or one of its certified dealers. Only King Controls and certified dealers are authorized to perform warranty evaluations and repairs.

If it is determined that the unit needs to be returned, return COMPLETE product, freight prepaid, to :
King Controls, 11200 Hampshire Ave. S. Bloomington, MN 55438-2453. If inspection shows the trouble is caused by defective workmanship or material, King Controls will repair (or at its option, replace) without charge.

This warranty does not apply where:

- The product has been abused, misused, improperly installed or improperly maintained.
- Repairs have been made or attempted by others that are not certified by King Controls to do such repairs.
- Repairs are required because of normal wear and tear.
- Alterations have been made to the product.

In no event shall King Controls be liable for any indirect, incidental, or consequential damages from the sale or use of the product. This disclaimer applies both during and after the term of the warranty.

King Controls disclaims liability for any implied warranties, including implied warranties of “merchantability” and “fitness for a specific purpose,” after the one year term of this warranty.

This warranty gives you specific legal rights, and you may also have other rights, which vary from state to state. Some states do not allow the exclusion or limitation of incidental or consequential damages, so the above limitation or exclusion may not apply to you. Some states do not allow limitations on how long an implied warranty lasts, so the above limitation may not apply to you.



11200 Hampshire Avenue South, Bloomington, MN 55438-2453
Phone: (800) 982-9920 Fax: (952) 922-8424

www.kingcontrols.com