

SMARTTIRE

INSTALLATION GUIDE

1

DISPLAY & RECEIVER

1. Connect the display cable into the back of the display and, using the included velcro, mount the display to the dash in a clean and easily viewable location.
2. Mount the receiver within reach of the display cable and near the location that the antenna(e) wires will enter the cab. The receiver should be mounted under the dash or under the driver seat if necessary.
3. Wire the receiver to the vehicle connecting the positive (red) wire to a fused, ignition keyed circuit and the negative (black) wire to ground.

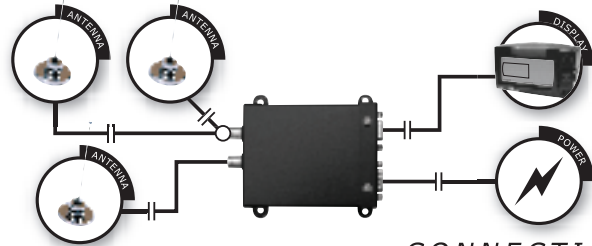
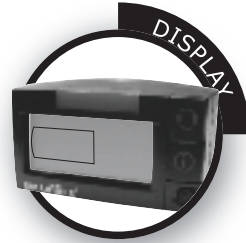

CONNECTION DIAGRAM

2

ANTENNA

1. Assemble the antenna(e). Be sure to install the rubber washer and tighten the assembly using a wrench.
2. Magnetically mount the antenna(e) to the underside of the vehicle so that it is pointed down or toward the rear of the vehicle with a clear line of sight to the tires and as much ground clearance as possible (see Sensor & Antenna Guide for locations). Antenna(e) may be adhered to frame rails, bumpers, and/or the tow-hitch as required.
3. Run the cables along the frame rails and into the cab to the receiver. Be sure to avoid moving parts and excessive heat. Starting at the antenna, attach the cables to the underside of the vehicle using the included cable ties.
4. With the power turned off, connect the display, antenna(e), and power cables to the appropriate ports on the receiver (see Connection Diagram in section 1). Coil the unused antenna cable and store it in an appropriate location free from moving parts and excessive heat.

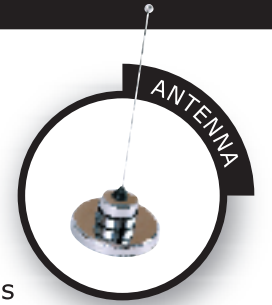

SENSOR & ANTENNA LOCATION DIAGRAM

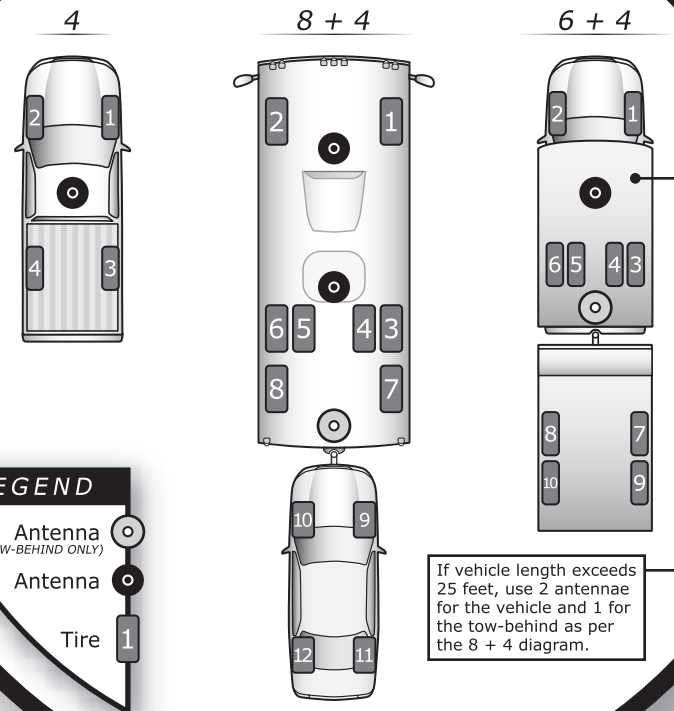

LEGEND

- Antenna (TOW-BEHIND ONLY)
- Antenna
- Tire 1

If vehicle length exceeds 25 feet, use 2 antennae for the vehicle and 1 for the tow-behind as per the 8 + 4 diagram.

3

SENSORS

Please read this section carefully and follow each step precisely to ensure that you do not damage a sensor and that the sensors are installed in the correct locations. Each sensor is pre-programmed in the receiver to a specific wheel on the vehicle. Use the above chart to match the number on the sensors to their pre-programmed wheel positions.

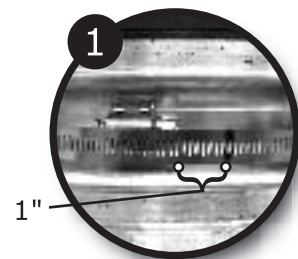

- 1-3. Wrap the strap around the rim and mark it 1" past the worm gear. Cut the strap at the mark and slide on the sensor.

4. Position the strap-mounted sensor at the valve in the lowest point of the drop center well.

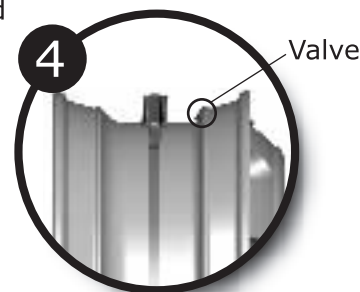

5. With the sensor positioned at the valve and the worm-gear positioned 3" away from the sensor, hand tighten the strap until the sensor can not be moved.

CAUTION: Do not over tighten!
(Reference Torque = 35 in-lbs / 4 Nm)

6. Indicate the location of the sensor by applying the supplied rim label to a clean and dry location on the outside of the rim flange.

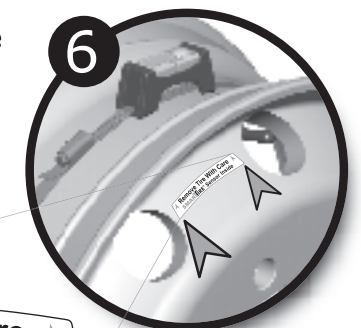

Remove Tire With Care
SMARTTIRE® Sensor Inside

FLIP FOR STEP
4

4A

MOUNTING THE TIRES BY MACHINE

Please read this section carefully and follow each step precisely to ensure that you do not damage a sensor.

1. Place the rim on the turntable of a tire-mounting machine so that the mount head is at 12 o'clock with the sensor at 7 o'clock.
2. Starting from the mount head, manually depress the bottom bead of the lubricated tire over the rim flange and into the drop center well until its pinch point is approximately 3" (7.5 cm) before the sensor.
3. Advance the turntable clockwise using the mount head to guide the rest of the bottom bead over the flange and onto the rim. When done properly, the bead will slip over the flange without contacting the sensor.
4. Repeat steps 1, 2 & 3 for the top bead. Do not allow the pinch point to slip as the rim rotates or the sensor could be broken.
5. Finish installation as normal. (Seat the beads, install the valve core, inflate to the recommended cold inflation pressure, balance tires and mount the wheels).

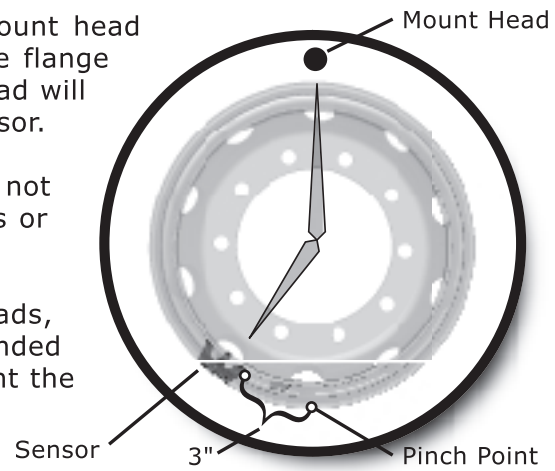

4B

MOUNTING THE TIRES BY HAND

It is very easy to avoid damaging a sensor when mounting a tire using tire irons. Simply mount the tire as you would normally while taking care to avoid the sensor. The easiest way to avoid contacting the sensor is to orient the tire so that the beads are first pushed under the rim flange directly opposite the sensor and then worked over the flange toward the sensor.

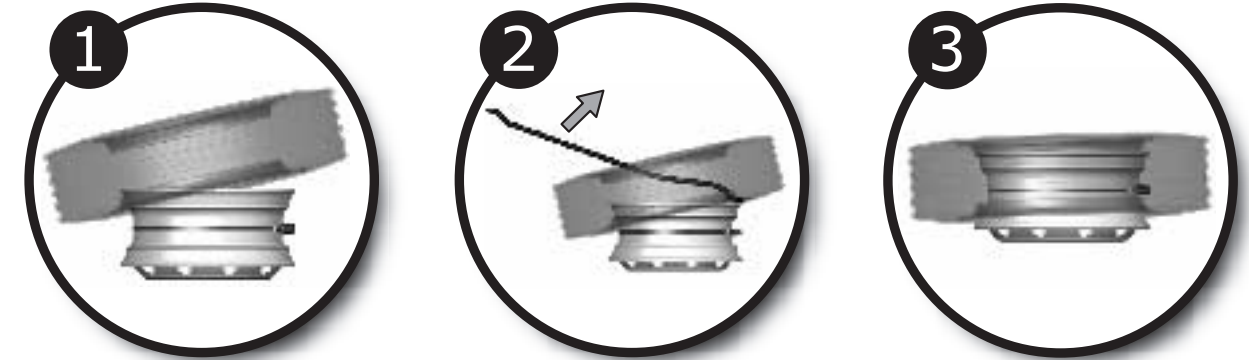

5

REMOVING A TIRE AFTER A SENSOR HAS BEEN INSTALLED

Please read this section carefully and follow each step precisely to ensure that you do not damage a sensor.

1. After removing the wheel from the vehicle and deflating the tire completely, unseat the beads with the bead breaker shoe directly opposite the valve in order to avoid the sensor. The sensor should be located at the valve stem (the rim mounted decal should also indicate the sensor's location). Do not break the bead at or near the sensor.

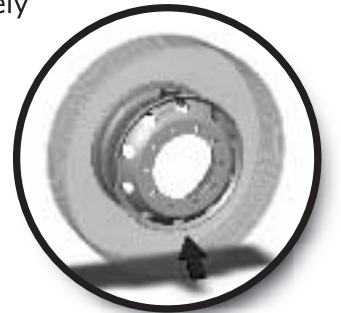

2. Place the rim on the turntable of a tire-mounting machine so that the mount head / bead lifting bar and the sensor are at 12 o'clock.
3. Lift the bead over the rim flange and advance the turntable clockwise to remove the top bead.
4. Repeat for the bottom bead.

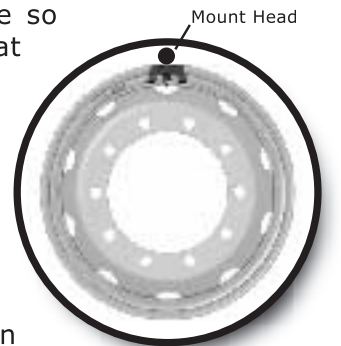

Note: When using tire irons instead of a tire mounting machine, unseat the beads opposite the sensor. Then remove the beads starting at the sensor, working the bead off away from the sensor.

OPEN FOR STEP
1

4A

MOUNTING THE TIRES BY MACHINE

Please read this section carefully and follow each step precisely to ensure that you do not damage a sensor.

1. Place the rim on the turntable of a tire-mounting machine so that the mount head is at 12 o'clock with the sensor at 7 o'clock.
2. Starting from the mount head, manually depress the bottom bead of the lubricated tire over the rim flange and into the drop center well until its pinch point is approximately 3" (7.5 cm) before the sensor.
3. Advance the turntable clockwise using the mount head to guide the rest of the bottom bead over the flange and onto the rim. When done properly, the bead will slip over the flange without contacting the sensor.
4. Repeat steps 1, 2 & 3 for the top bead. Do not allow the pinch point to slip as the rim rotates or the sensor could be broken.
5. Finish installation as normal. (Seat the beads, install the valve core, inflate to the recommended cold inflation pressure, balance tires and mount the wheels).

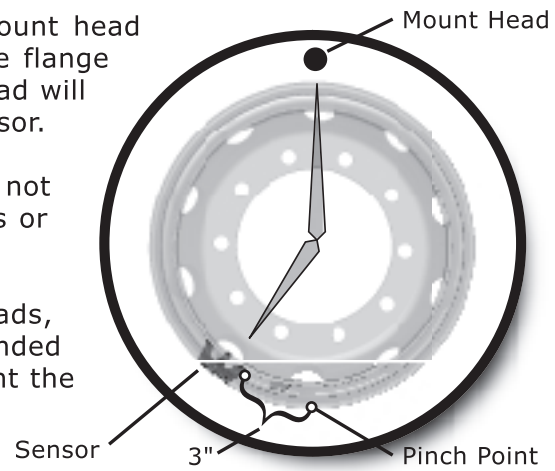

5

REMOVING A TIRE AFTER A SENSOR HAS BEEN INSTALLED

Please read this section carefully and follow each step precisely to ensure that you do not damage a sensor.

1. After removing the wheel from the vehicle and deflating the tire completely, unseat the beads with the bead breaker shoe directly opposite the valve in order to avoid the sensor. The sensor should be located at the valve stem (the rim mounted decal should also indicate the sensor's location). Do not break the bead at or near the sensor.

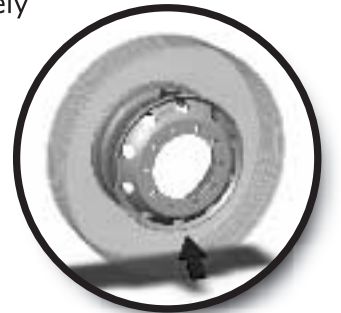

2. Place the rim on the turntable of a tire-mounting machine so that the mount head / bead lifting bar and the sensor are at 12 o'clock.
3. Lift the bead over the rim flange and advance the turntable clockwise to remove the top bead.
4. Repeat for the bottom bead.

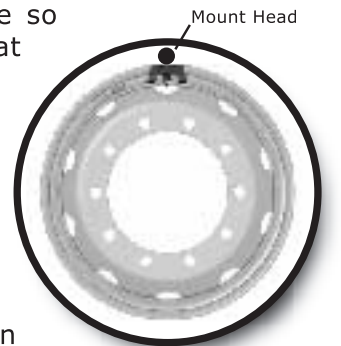

Note: When using tire irons instead of a tire mounting machine, unseat the beads opposite the sensor. Then remove the beads starting at the sensor, working the bead off away from the sensor.

OPEN FOR STEP
1

Suite 150, 13151 Vanier Place
Richmond, BC, Canada, V6V 2J1
info@smarttire.com
1.888.982.3001
www.smarttire.com



SMARTTIRE
ACTIVE TIRE PRESSURE MONITORING
FOR RECREATIONAL VEHICLES
INSTALLATION MANUAL

